

10'-0" X 10'-0"
STANDARD MANHOLE

One-Piece Manhole				
HEADROOM		SLAB	WALL	FLOOR
MIN.	MAX.			
3'-0"	7'-0"	7"	6" OR 8"	7"

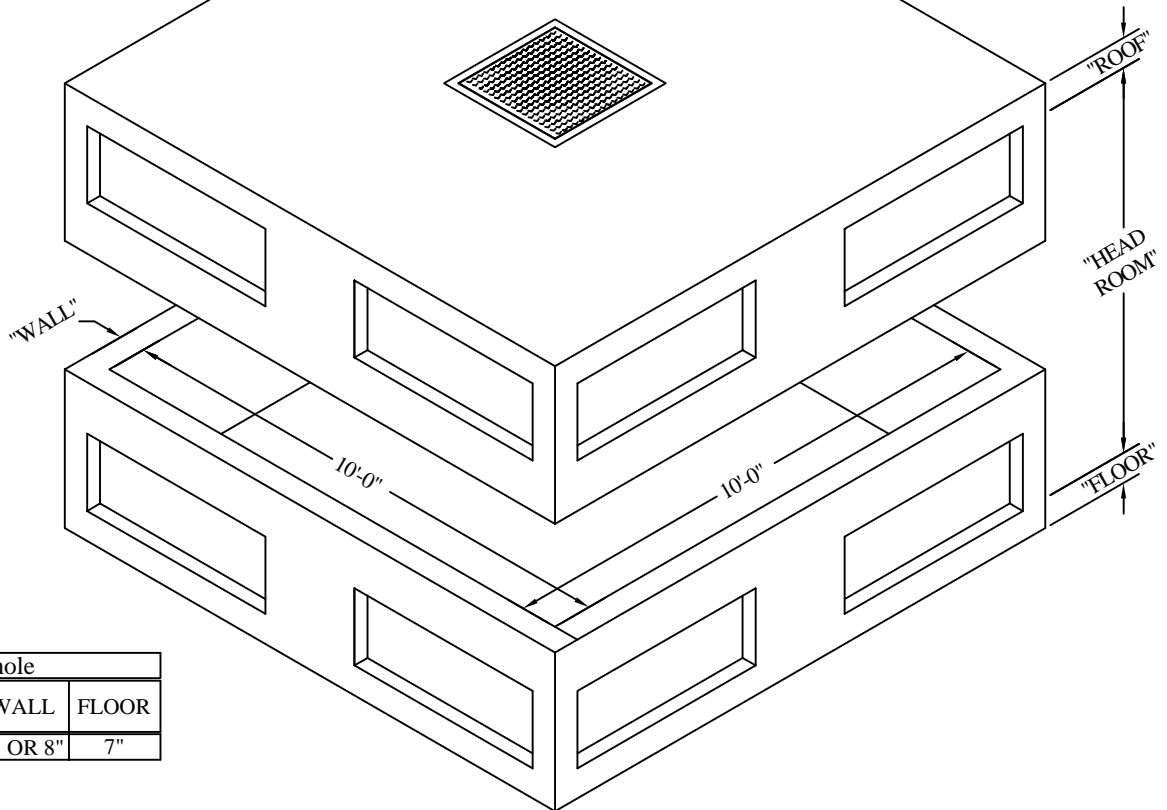
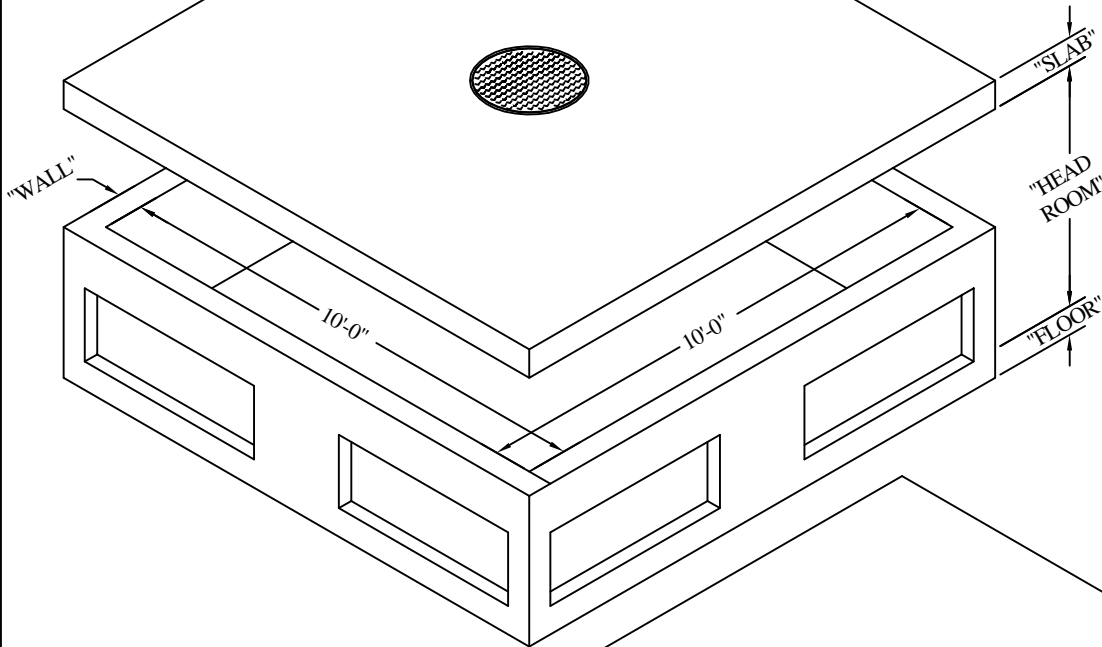

Two-Piece Manhole				
HEADROOM		ROOF	WALL	FLOOR
MIN.	MAX.			
6'-0"	14'-0"	7"	6" OR 8"	7"

AC MILLER
CONCRETE PRODUCTS, INC.
WWW.AC MILLER.COM

31 E. BRIDGE ST.
SPRING CITY
PA. 19475

PHONE:
(610) 948-4600
FAX:
(610) 948-9750

RT. 22 WEST
BLAIRSVILLE,
PA. 15717

PHONE:
(724) 459-5950
FAX:
(724) 459-9151

Precast Concrete Utility Vaults
10'-0" X 10'-0" Manhole
with Standard Knockout Panels

FILE NAME: 10x10 MANHOLE P1

DATE: 8/20/03

DRAWN BY: BTH

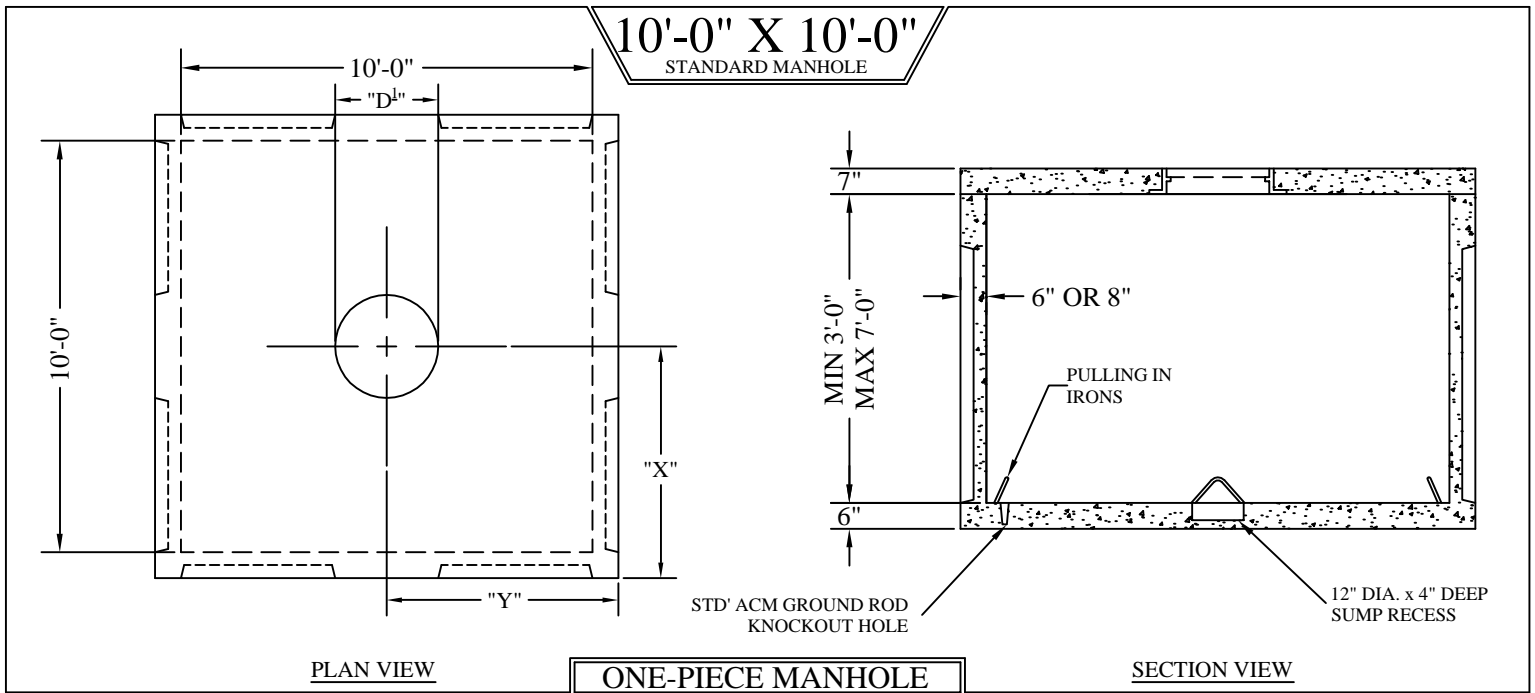

ONE-PIECE MANHOLE
TWO-PIECE MANHOLE

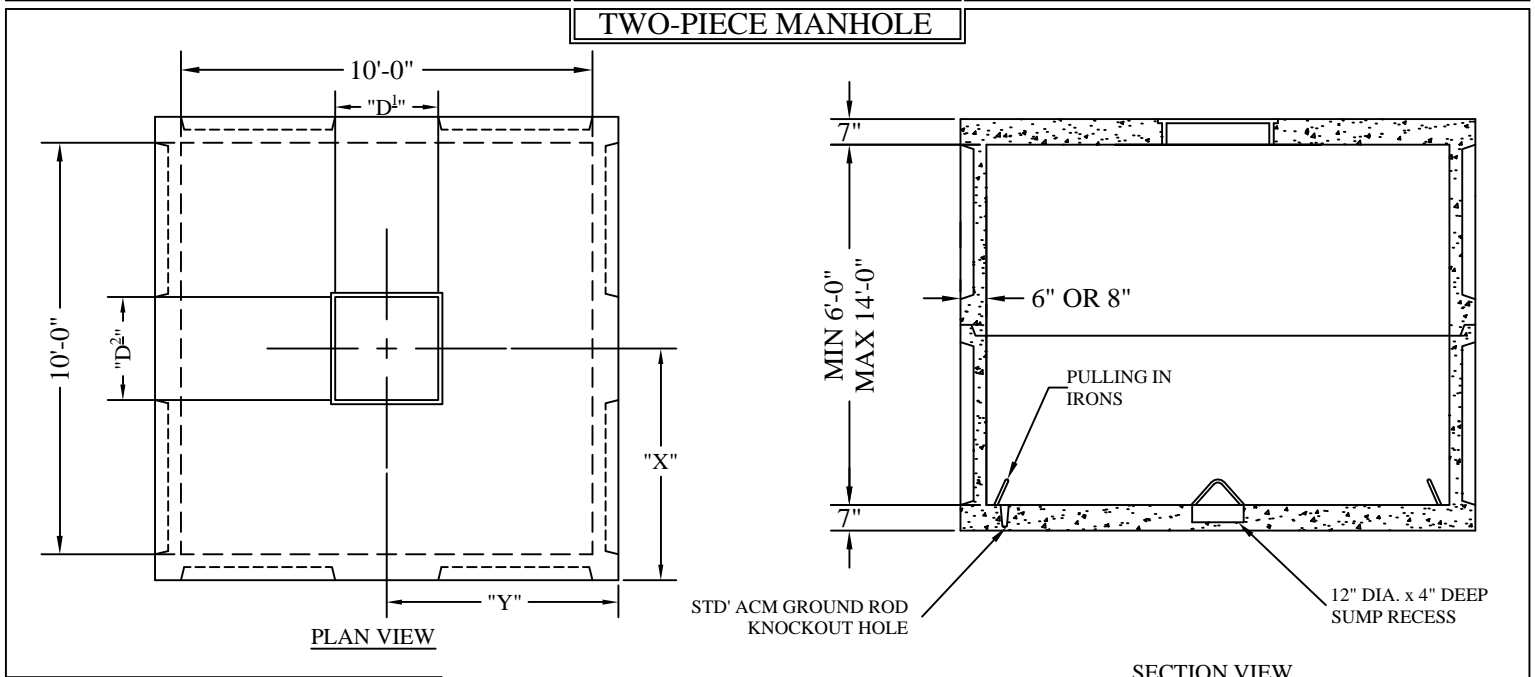

"X" = _____

"Y" = _____

"D¹" = _____

"D²" = _____

CIRCLE ALL THAT IS APPLICABLE.

FRAME AND COVER, HATCH OR NONE

IF HATCH OR FRAME AND COVER:

CAST IN SLAB OR SEPERATE

* PLEASE NOTE:
ACM USES INSIDE DIMENSIONS TO
DESCRIBE VAULT SIZE.

* FOR ANY ADDITIONAL
INFORMATION PLEASE CONTACT
A.C. MILLER SALES
REPRESENTATIVE

JOB: _____

CUSTOMER: _____

DRAWING ___ OF ___

LIVE LOAD: HS-20
EARTH COVER: 0 to 2 ft.
CONCRETE: 5000 psi AT 28 DAYS
REBAR: GRADE 60, ASTM A615 SPEC'S
PRECAST CONCRETE VAULT CONFORMS TO ASTM
C890 AND C913 SPECIFICATIONS

AC MILLER
CONCRETE PRODUCTS, INC.
WWW.AC MILLER.COM

31 E. BRIDGE ST. PHONE: (610) 948-4600
SPRING CITY FAX: (610) 948-9750
PA. 19475

RT.22 WEST PHONE: (724) 459-5950
BLAIRSVILLE, FAX: (724) 459-9151
PA. 15717

Precast Concrete Utility Vaults
10'-0" X 10'-0" Manhole
with Standard Knockout Panels